



Benjamin® Sheridan®

PNEUMATIC AIR RIFLES OWNER'S MANUAL

**Blue Streak® and Silver Streak® C9 Series .20 Caliber
and
397 Models, .177 Caliber and 392 Models, .22 Caliber**



**READ ALL INSTRUCTIONS AND WARNINGS IN THIS
MANUAL BEFORE USING THIS AIRGUN.**

FORM #544

CONGRATULATIONS!

Thank you for purchasing one of our precision made air rifles. We hope you share our enthusiasm for quality products.

Please read this owner's manual completely. And remember, this air rifle is not a toy. Treat it with the same respect you would a firearm. Always carefully follow the safety instructions found in this owner's manual and keep this manual in a safe place for future use.

If you have any questions concerning your new air rifle, please contact us.

Sincerely,

Benjamin Sheridan Corporation
2600 Chicory Road
Racine, WI 53403 U.S.A.

⚠ WARNING: NOT A TOY. ADULT SUPERVISION REQUIRED. MISUSE OR CARELESS USE MAY CAUSE SERIOUS INJURY OR DEATH. MAY BE DANGEROUS UP TO 475 YARDS (435 METERS).

READ ALL INSTRUCTIONS BEFORE USING.

BUYER AND USER HAVE THE DUTY TO OBEY ALL LAWS ABOUT THE USE AND OWNERSHIP OF THIS AIRGUN.

THIS AIRGUN IS INTENDED FOR USE BY THOSE 16 YEARS OF AGE OR OLDER.

2

STEPS FOR SAFE SHOOTING

Step 1.	Learning the Parts of Your New Air Rifle	4
Step 2.	Operating the Safety	5-6
Step 3.	Pumping the Air Rifle	7
Step 4.	Loading and Unloading Pellets	8-9
Step 5.	Aiming and Firing Safely	9-11
Step 6.	Removing a Jammed Pellet	12
Step 7.	Maintaining Your Air Rifle	13-14
Step 8.	Reviewing Safety	15
Step 9.	Choosing Targets	15

Step 1. Learning the Parts of Your New Air Rifle

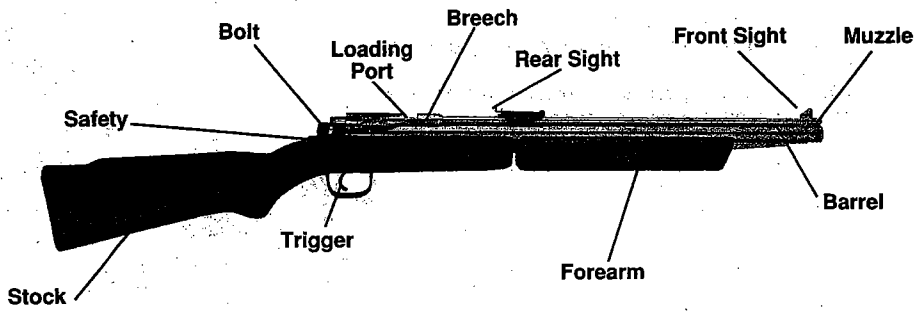

4

Step 2. Operating the Safety

NOTE: BE SURE THE RIFLE IS "OFF SAFE" BEFORE COCKING (Fig. 2). FAILURE TO FOLLOW THE PROCEDURE LISTED BELOW MAY RESULT IN JAMMING THE FIRING MECHANISM.

A. Cocking the Air Rifle

- Point the rifle in a safe direction.
- Push bolt handle up and then pull it all the way to the rear. (Fig. 1)
- Close the bolt by pushing the bolt forward and then downward into the locked position.

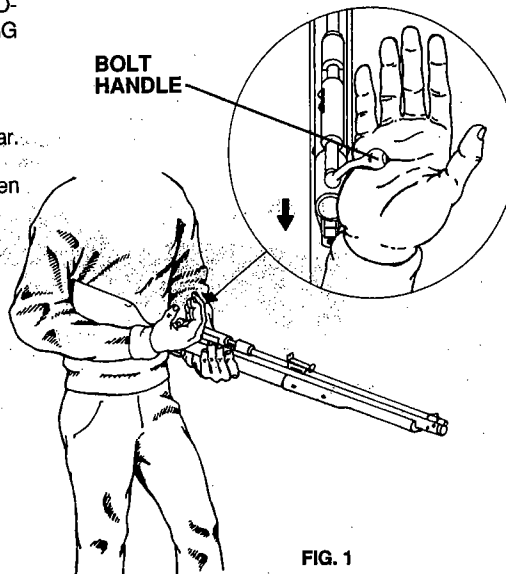

FIG. 1

B. Putting the Air Rifle On Safe

⚠ WARNING: THE RIFLE MUST BE COCKED BEFORE YOU CAN PUT IT ON SAFE.

- To put the air rifle on safe, pull the safety all the way back with your thumb. The safety is not on unless it is pulled all the way back so the red dot is covered and the "S" is completely visible. (Fig 2)
- Even when the safety is on you should continue to handle the rifle safely. Don't point the rifle at anything you don't intend to shoot.
- To take the air rifle off safe, push the safety all the way forward. When you can see the red dot behind the safety the gun is off safe and ready to be fired. (Fig. 2)

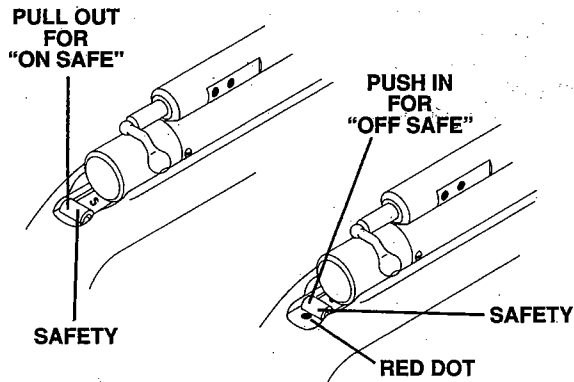

FIG. 2

6

⚠ WARNING: KEEP THE AIR RIFLE "ON SAFE" UNTIL YOU ARE ACTUALLY READY TO SHOOT. THEN PUSH IT TO "OFF SAFE."

Step 3. Pumping the Air Rifle

- Put the rifle on safe. (Step 2)
- Open the forearm all the way until it stops. (Fig. 3)
Close it with a smooth stroke using the heel of your hand. Don't pinch hand or fingers when the forearm closes. Keep your finger off the trigger while pumping.
- Be sure to use at least 2 pumps to prevent the barrel from jamming with a pellet.
- Do not twist forearm while pumping. Use straight strokes to prevent breakage.

⚠ WARNING: NEVER PUMP YOUR GUN MORE THAN EIGHT TIMES. OVER PUMPING GIVES ONLY A SLIGHT INCREASE IN POWER AND WILL CAUSE MAJOR DAMAGE TO YOUR GUN. PUMPING MORE THAN EIGHT TIMES MAY ALSO LEAVE A SMALL AMOUNT OF AIR IN THE GUN WHICH MAY ALLOW YOU TO FIRE A SECOND SHOT WITHOUT ADDITIONAL PUMPING.

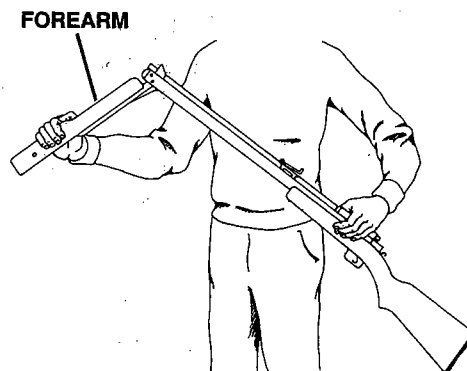

FIG. 3

7

Step 4. Loading and Unloading Pellets

⚠ CAUTION: USE .20 CALIBER PELLETS ONLY IN YOUR C9 SERIES RIFLE. USE .177 CALIBER PELLETS ONLY IN YOUR MODEL 397 AIR RIFLE. USE .22 CALIBER PELLETS ONLY IN YOUR MODEL 392 AIR RIFLE. USE OF ANY OTHER AMMUNITION CAN CAUSE INJURY TO YOU OR DAMAGE TO YOUR RIFLE.

A. Loading Pellets

- Put the rifle on safe. (Step 2)
- Point the rifle in a safe direction.
- Pull the bolt all the way back. (Step 2A)
- Place one pellet, nose forward, in the loading port (breech). (Fig. 4)
- Lightly push the pellet into the barrel by closing and locking the bolt. **DO NOT** jam the bolt forward. This will damage your rifle.
- Be sure the bolt is closed before firing. If it is not closed and fully locked, air may remain in the rifle and the pellet may not be discharged.

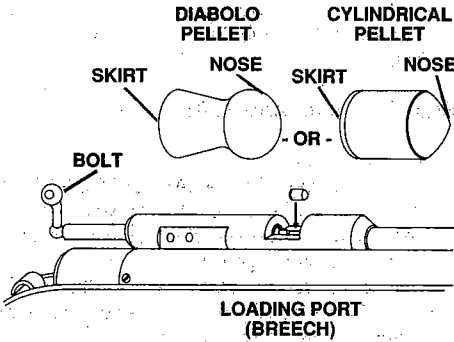

FIG. 4

8

B. Unloading Pellets

- Put the rifle on safe. (Step 2)
- Pump the rifle 8 times, aim in a **SAFE DIRECTION**, take off safe and fire.
- Another way of unloading your rifle is to follow the directions listed under Step 6 - Removing a Jammed Pellet.

Step 5. Aiming and Firing Safely

A. Aiming the Rifle

- Always aim your rifle in a **SAFE DIRECTION**. When you are sure of your target and backstop and the area around the target is clear, take the rifle off safe and squeeze the trigger to fire.
- Don't shoot at hard surfaces or at the surface of water. The pellet may bounce off and hit someone or something you had not intended to hit.
- The rifle is correctly aimed when the front sight blade is positioned exactly in the notch of the rear sight. The top of the front sight blade should be even with the top of the notch in the rear sight. The bullseye should appear to rest on the top of the front sight. (Fig. 5)

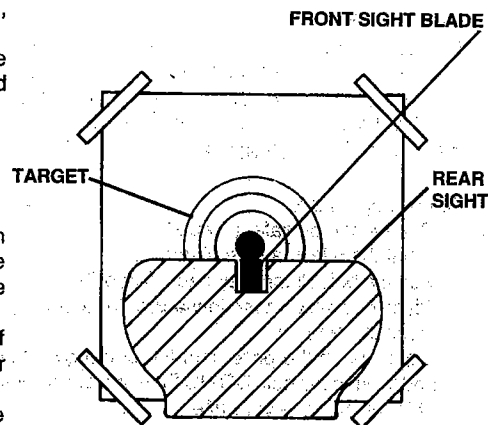

FIG. 5

9

B. Sight Adjustment - Open Sights

- The rear sight may be adjusted to shoot higher or lower (elevation). Turn the elevation screw clockwise to make the pellet hit higher on the target. Turn the elevation screw counterclockwise to make the pellet hit lower on the target. (Fig. 6)
- The rear sight may also be adjusted to shoot right or left (windage). To make the pellet hit further to the left on the target, loosen the windage screw on the right side of the sight and tighten the windage screw on the left side of the sight. To make the pellet hit further to the right on the target, loosen the windage screw on the left side of the sight and tighten the windage screw on the right side of the sight. (Fig. 6)

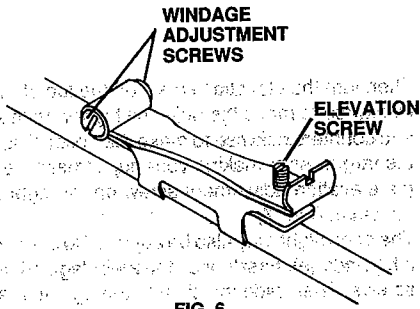

FIG. 6

C. Sight Adjustment - Peep Sights

Models CBW9, CW9, 397W, S397W, 392W and S392W only are equipped with a Williams receiver peep sight. These peep sights can also be ordered as an accessory from the factory.

- The peep sight may be adjusted to shoot higher or lower (elevation). First loosen the elevation adjustment screw on the right front side of the sight.

10

Then turn the elevation screw on the top of the sight clockwise to make the pellet hit higher on the target and counterclockwise to make the pellet hit lower on the target. After making your adjustments retighten the elevation adjustment screw on the right side of the sight. (Fig. 7)

- The peep sight may also be adjusted to shoot right or left (windage): First loosen the 2 windage adjustment screws. Then slide the sight to the right to make the pellet hit further to the right on the target or slide the sight to the left if you want to make the pellet hit further to the left on the target. After making your adjustments, retighten the windage adjustment screws. (Fig. 7)

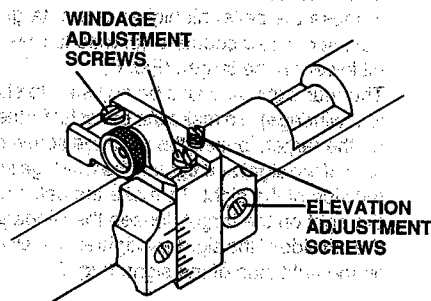

FIG. 7

Step 6. Removing a Jammed Pellet

- A. Don't reload.
- B. Put the rifle on safe. (Step 2)
- C. With the bolt in the open position, insert a cleaning rod (cleaning rods can be ordered from the factory) into the muzzle end of the barrel and gently push the jammed pellet into the pellet loading port (forward of the bolt). (Fig. 8) Don't try to reuse that pellet again.
- D. If for some reason you are unable to unjam your rifle, return it to the factory and we will unjam it for you free of charge during the warranty period.

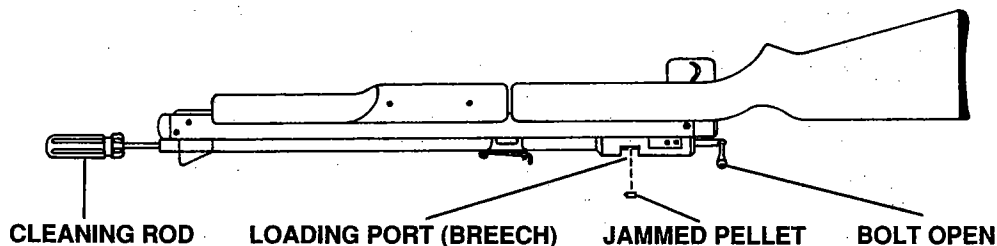

FIG. 8

Step 7. Maintaining your Air Rifle

TROUBLE SHOOTING GUIDE

PROBLEMS	Safety in "On" position	Gun not cocked	Bolt in open position	Gun not pumped	Gun not pumped to recommended number of pumps	Barrel plugged	Lack of lubrication or too much lubrication	Re-used ammunition	Pellet loaded backwards	Use of wrong type or cal. ammo	Loading more than one pellet	Damaged muzzle end of Barrel	Sights not adjusted
INACCURACY				●		●	●	●	●	●	●	●	●
GUN FAILS TO SHOOT	●	●	●	●	●	●	●	●	●	●	●	●	
LOW POWER				●		●	●	●	●	●			
BARREL PLUGGED				●		●	●	●	●	●	●		

- When lubricating your air rifle, use our #088 Lubricating Oil (available for order from the factory). DO NOT use gun oil or any other oil which contains solvents.
- Both the barrel and tube are made of a rust resistant, hard, non-ferrous alloy and require no special treatment.

- Only the pump lever pivot point, crosshead pivot point, and the lever pivot rivet should occasionally be oiled LIGHTLY (one or two drops). Don't over-oil. This can cause damage to your rifle. (Fig. 9)
- If the accuracy of your rifle falls off, run a firm but free fitting patch through the barrel. Be sure to use a cleaning rod of the proper size that will not damage the barrel.
- Tampering with the gun or attempts to change the gun in any way make it unsafe to use. If you drop your gun, check it to see that it works properly before you use it again. If anything seems changed, like a shorter or weaker trigger pull, this may mean worn out or broken parts. Don't use it again until you've had it checked by our factory service department.

FIG. 9

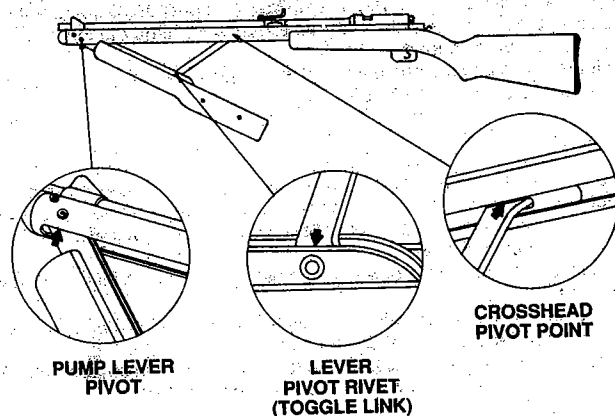

14

Step 8. Reviewing Safety

- Don't point at anything you do not intend to shoot. Always aim in a SAFE DIRECTION.
- Always wear shooting glasses to protect your eyes.
- Don't pinch hands or fingers when closing forearm.
- Use .20 cal. pellets only in your C9 Series rifle. Use .177 cal. pellets only in your Model 397. Use .22 cal. pellets only in your Model 392. Never reuse ammunition.
- Don't shoot at hard surfaces or at the surface of water. The pellet may bounce off and hit someone or something you had not intended to hit.
- Always keep the air rifle on safe until you are ready to shoot.
- Stop using a backstop if it becomes worn. Place backstop in a location that will be safe should the backstop fail.
- Do not attempt to disassemble or tamper with your gun. Return your airgun to the factory for repair.
- Always handle your rifle as if it were loaded.
- Always check to see if the rifle is on safe and unloaded when getting it from another person or from storage.
- Don't put the rifle away loaded or charged with air.

Step 9. Choosing Targets

- Always choose your targets carefully. It is best to shoot at bullseye targets which are attached to a safe backstop such as the 850 Target Trap. (Target Trap can be ordered directly from the factory.) A heavy blanket should be hung behind the Target Trap to prevent ricochet or pellets bouncing off should you miss the backstop. Always wear shooting glasses to protect your eyes.
- Don't shoot at hard surfaces or at the surface of water. The pellet may bounce off and hit someone or something you had not intended to hit.
- Your backstop should be checked for wear before and after each use. Stop using any backstop if the surface is worn or damaged or if the pellet bounces off or ricochets.
- Your airgun is designed for target shooting and is suited for both indoor and outdoor use. Always remember to place your target carefully. THINK what you will hit if you miss your target!

SPECIFICATIONS

Mechanism:	Bolt Action
Caliber:	
C9 Series:	.20 cal. (5 mm) Lead Airgun Pellet
392 Models:	.22 cal. (5.5 mm) Lead Airgun Pellet
397 Models:	.177 cal. (4.5 mm) Lead Airgun Pellet
Capacity:	Single Shot
Weight:	
C9 Series:	6 lbs. (2.7 kg)
392/397 Models:	5 ½ lbs. (2.5 kg)
Overall Length:	
C9 Series:	36 ½ inches (92.7 cm)
392/397 Models:	36 ¼ inches (92.1 cm)
Sights:	
Rear:	Adjustable Open or Peep
Front:	High Ramp Blade
Barrel:	
C9 Series:	Rifled brass, right hand, 6 grooves, 1 turn in 12"
392/397 Models:	Rifled brass, right hand, 6 grooves, 1 turn in 14"
Power Source:	Pneumatic Pump Action
Stock & Forearm:	American Walnut
*Velocity at 8 pumps:	
C9 Series:	670 FPS
392 Models:	685 FPS
397 Models:	800 FPS

*Many factors affect velocity, including brand of projectile, type of projectile, oiling of gun, barrel condition and temperature.

REPAIR SERVICE

- If your rifle needs repair, we recommend you send it to the factory. Your rifle requires special tools and fixtures to repair it. If you take it apart, you probably will not be able to reassemble it correctly. Benjamin Sheridan assumes no warranty responsibility in this case.
- When shipping your rifle to the factory, pack it as carefully as possible and **INSURE IT FOR FULL VALUE**. Your note as to the problem and cause of same, if possible, will be helpful.

A SPECIAL CUSTOMER SERVICE

Benjamin Sheridan will unjam your rifle at no cost during the warranty period.

LIMITED ONE YEAR WARRANTY

This product is warranted to the retail consumer for one year from date of retail purchase against defects in material and workmanship and is transferable. To register the serial number of your gun, please return the airgun registration form. The warranty is not conditioned on the return of the card.

WHAT IS COVERED

Replacement parts and labor. Transportation charges to consumer for repaired product.

WHAT IS NOT COVERED

Transportation charges to Benjamin Sheridan for defective product. Damages caused by abuse or failure to perform normal maintenance—see Owner's Manual. Sales outside of the United States. Any other expense. **CONSEQUENTIAL DAMAGES, INCIDENTAL DAMAGES, OR INCIDENTAL EXPENSES, INCLUDING DAMAGE TO PROPERTY. SOME STATES DO NOT ALLOW THE EXCLUSION OR LIMITATION OF INCIDENTAL OR CONSEQUENTIAL DAMAGES, SO THE ABOVE LIMITATION OR EXCLUSION MAY NOT APPLY TO YOU.**

HOW TO OBTAIN WARRANTY PERFORMANCE

Attach to product your name, address, description of problem, phone number and proof of date of retail purchase (sales slip). Package and return product to Benjamin Sheridan Corporation, transportation charges prepaid.

IMPLIED WARRANTIES

ANY IMPLIED WARRANTIES, INCLUDING THE IMPLIED WARRANTIES OF MERCHANTABILITY AND FITNESS FOR A PARTICULAR PURPOSE, ARE LIMITED IN DURATION TO ONE YEAR FROM DATE OF RETAIL PURCHASE. SOME STATES DO NOT ALLOW LIMITATIONS ON HOW LONG AN IMPLIED WARRANTY LASTS, SO THE ABOVE LIMITATIONS MAY NOT APPLY TO YOU.

To the extent any provision of this warranty is prohibited by federal, state or municipal law which cannot be preempted, it shall not be applicable. This warranty gives you specific legal rights, and you may also have other rights which vary from state to state.