

INSTRUCTION SHEET FOR NO. 340-342-347 BENJAMIN SUPER SINGLE SHOT AIR RIFLES KEEP FOR FUTURE REFERENCE

THIS GUN HAS BEEN CAREFULLY TESTED for compression and accuracy by shooting it several times before passing our inspection. The operation of same is under your control and it will give satisfactory results if instructions are carefully followed.

KNOW YOUR GUN. It is important that you understand how gun operates to obtain satisfactory performance. Use gun often as frequent operation keeps piston and valves flexible. Keep (1) or (2) pumps in Air Gun when not in use to help keep valves seated. If valves leak after gun has been stored, they should be replaced.

USUALLY THERE IS NOTHING SERIOUSLY WRONG with a new gun. Any failure is due to damage in shipment, or one of the following reasons: **SAFETY IS ON;** Trigger assembly is not securely attached to gun barrel; gun has been pumped up too much; shot barrel is jammed; valve is unseated. Bolt guide screw is damaged or missing; Bolt Lock Cam needs adjustment.

BEFORE PUMPING RIFLE UP PUT SAFETY ON.

BEFORE PUMPING AIR RIFLE: ASSEMBLE BARREL AND STOCK-TIGHTEN SCREW SECURELY. Then put left hand around breech of gun barrel and fore-end of stock (as illustrated); pull No. 34102 Pump Lever out until No. 3452 Pump Washer passes air intake hole. Push No. 34102 Pump Lever back against No. 3422 Pump Barrel, being careful to avoid pinching fingers. Pump (4) or (5) strokes for ordinary use; to shoot hard, pump gun (10) or (12) times. It is necessary to pump these models up after each shot.

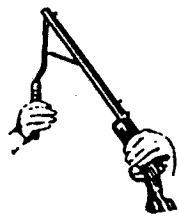

SHOOTING FORCE IS ADJUSTABLE. Three or four pumps are required for shooting Ammo out. You can determine number of pumps required for various uses after a little practice.

IF GUN IS HARD TO PUMP you may be pumping against a full Air Chamber, or Pump Cylinder is dry. If Pump Piston binds, lubricate with light machine oil Felt Washers No. 3436. Do not lubricate excessively as oil may be forced into Air Chamber when pumping; this may damage valve packing.

THERE IS NO ADVANTAGE IN PUMPING GUN UP TOO MUCH as excessive internal pressure will not permit Outlet Valve to open up wide when firing, owing to pressure in Air Chamber being greater than impact of Hammer on firing pin which releases shooting force. Excessive pumping may bend or buckle Pump Lever. Both Valves are often damaged due to Valve Seats forming a groove in Valve packing and must be replaced, otherwise all of the air pressure

is not released from Air Chamber when firing, even in New Guns.

OVERPUMPING may spring both Barrels and loosen Shot Barrel at muzzle end causing Gun to shoot off target. Excessive pumping may bend or buckle Pump Lever or crack Pump Handle as Gun will be harder to pump. To release excessive internal pressure, fire Gun blank (dry) as often as it is necessary to empty the Air Chamber.

SOMETIMES VALVES LEAK ON FIRST PUMP. If there is no pressure in Air Chamber when you start pumping, cock Hammer by pulling Bolt all the way back; this takes pressure of Hammer off Outlet Valve until Air pressure is raised in Air Chamber by pumping gun several times and both Valves usually seat themselves. Clean or replace Valves when necessary.

AFTER AIR RIFLE IS PUMPED UP turn Bolt Handle to the left and upwards and pull Bolt all the way back until No. 343 Trigger engages No. 3492 Hammer when you will hear a click.

No. 340 BENJAMIN AIR RIFLE SHOTS LEAD OR STEEL AIR RIFLE SHOT. After No. 3465 Bolt is pulled back **PRESS A ROUND AIR RIFLE SHOT IN END OF BOLT,** which is bored out for this purpose, with index finger (not in hole in side of Bolt which is for another purpose); push Bolt in and lock it by turning Handle to right which seals breech end of shot barrel and prevents air from escaping at this point when gun is fired (unless Bolt Lock Cam adjustment has been disturbed), also advances shot to firing position; do not apply excessive force on Bolt Handle when locking Bolt. **ROUND SHOT WILL NOT ROLL OUT** when aiming below level unless end of Bolt is damaged. We do not make Lead or Steel Air Rifle Shot; we handle the best quality available. You can screw and shoot and use only full round shot for better shooting. Cal. .177 Darts can be used in this model if metal shanks are smooth (without burrs); they do not damage Shot Barrel.

YOU CAN USE CAL. .177 BENJAMIN H-C PELLETS in No. 340 BENJAMIN AIR RIFLE for accurate shooting; do not change Bolt. After Bolt is pulled back, hold Gun in vertical position and drop solid round end of Pellet in breech opening of Shot Barrel; push Pellet forward with index finger until hollow end is flush with end of Shot Barrel. Close Bolt gently and lock it.

No. 342 BENJAMIN AIR RIFLE shoots Cal. .22 BENJAMIN H-C PELLETS; DARTS can be used in this model if metal shanks are smooth (without burrs) so they do not damage rifling in Shot Barrel.

No. 347 BENJAMIN AIR RIFLE shoots Cal. .177 BENJAMIN H-C PELLETS; DARTS can be used in this model if metal shanks are smooth (without burrs) so they do not damage rifling in Shot Barrel.

TO LOAD PELLETS pull Bolt back until it engages Trigger; place BENJAMIN H-C PELLET in breech opening (solid round end forward) ahead of Bolt, push Bolt forward and lock it; this advances Pellet to firing position.

USE BENJAMIN H-C PELLETS FOR BEST RESULTS. WE DO NOT GUARANTEE SATISFACTORY PERFORMANCE WITH INFERIOR AMMUNITION. If your Dealer cannot furnish BENJAMIN H-C PELLETS order direct from FACTORY. DO NOT USE PELLETS OVER AGAIN.

ALWAYS KEEP No. 3455 SAFETY ON until you are ready to shoot to prevent accidental discharge. Safety is located at Breech of Gun--See No. 3455 on Drawing. To put Gun on Safe, Cock Hammer. Pull Safety back with thumb until "S" appears, Gun is now on Safe. When ready to fire push Safety forward.

DO NOT PUT GUN AWAY WHEN CHARGED WITH AIR AND DO NOT FIRE GUN UNLESS IT IS CHARGED WITH AIR. No. 3403 Hair Trigger has smooth pull between 2 and 4 pounds same as used in fire arms.

USE GUN OFTEN as frequent operation keeps Valves and Pump Washer flexible. DO NOT OIL VALVES or allow any oil to reach Valves from Pump Cylinder. We usually use oil proof Valve packing, however, we reserve the right to substitute other suitable materials when it is not available.

ALL COMPRESSED AIR DEVICES USE A PLUNGER OR PISTON for Compressing Air into a tank or chamber which is equipped with valves, and the valves must be seated to hold air pressure. The following have been replaced by 34-52A & 34207 - After 6-1-77

THESE GUNS HAVE SELF EXPANDING HYCAR PUMP WASHER ASSEMBLY attached to end of Pump Rod, consisting of No. 3452 Hycar Pump Washer on No. 3453 Pump Fitting; No. 3454 Lock Washer holds No. 3436 felt oiler on No. 3453 Fitting. YOU CAN REPLACE HYCAR PUMP WASHER and FELT OILERS when worn or damaged. The Air is Compressed with a hand operated Pump and forced into Air Chamber through Inlet Valve. Outlet Valve releases Compressed Air when Gun is Fired.

TO REMOVE PUMP ASSEMBLY, pull 34102 Pump Lever up as far as it will go, push out 34111 Muzzle Plug Pin, push out 34111 Lever Hinge Pin; pull 3424 Muzzle Plug out. Pump Lever Assembly will drop thru slot in Gun Barrel. Push Pump Lever Assembly forward until 34125 Link Coupling Pin is in line with 34111 Hinge Pin hole in Barrel; push 34125 Link Coupling Pin out. Pump Lever Assembly will drop out; remove 3442 Link Coupling with 3418 Pump Rod Assembly.

Adjust length of Pump stroke if necessary as follows; loosen 34121 Pump Rod Lock Nut and turn 3442 Link Coupling to shorten or increase overall length (7-3/8") of Pump Rod assembly; tighten 34121 Lock Nut.

TO PUT PUMP ASSEMBLY BACK IN PUMP BARREL, clean inside of Pump Barrel thoroughly with dry rag to remove any foreign matter. Hold Pump Barrel horizontally in one hand, with slot on top, and insert 3452 HYCAR Pump Washer mounted on end of Pump Rod in Muzzle End of Pump Barrel; guide HYCAR Pump Washer into Pump Barrel with fingers while turning Pump Rod gently right and left. Push Pump Washer to end of slot in Pump Barrel and guide Pump Washer into Pump Barrel with fingers while turning Pump Rod gently right and left. Replace Pump Lever Assembly by reversing operations for removing same.

IF GUN HAS NOT BEEN USED FOR SOME TIME and cannot be pumped up or does not hold AIR, it can be REPAIRED.

OUR WARRANTY REQUIRES PURCHASERS to mail Registration Card to Factory promptly and WRITE FACTORY about NEW GUNS that are not entirely satisfactory. Advise Model, when Gun was received or purchased, also price paid and what the Trouble is, etc., so we can recommend proper care or handling of gun. WE DO NOT REPLACE GUNS or authorize Dealers to exchange them -- UNDER WARRANTY.

WE GUARANTEE SATISFACTORY PERFORMANCE AND WILL SERVICE NEW GUNS purchased at Regular Prices FREE OF CHARGE under WARRANTY IF RETURNED TO FACTORY PREPAID within a reasonable time, (providing Registration Card was mailed to Factory promptly) and Guns have not been damaged or abused and do not show excessive wear.

SOME OF OUR DEALERS are equipped to SERVICE BENJAMIN under WARRANTY and to repair worn guns. Ask us for the local Authorized Repair Depot in your Area, or advise nearest Large Cities.

YOU CAN MAKE YOUR OWN REPAIRS. ORDER Valve Tool and Parts from Factory if not available from Dealer. Itemize Parts by number in accordance with Price List. Advise Model and enclose Payment (including Handling, Packing and Postage) with Orders. WE DO NOT SHIP C.O.D.

BE SURE THAT AIR IS DISCHARGED FROM AIR CHAMBER BEFORE REMOVING VALVES.

TO REMOVE VALVES take out all the parts in breech end of large barrel down to No. 3440 Outlet Valve Lock Screw. Insert small end of Valve Tool in square hole of Outlet Valve Lock Screw and remove Outlet Valve Lock Screw by unscrewing it. You can hold Valve Tool in vise horizontally and push breech end of large barrel over small end of Valve Tool, then turn gun slowly to left which will loosen Outlet Valve Lock Screw; do not use wrench or pliers on gun barrel. Or you can hold gun barrel in a vise between two wooden jaws which have been bored out to accommodate same; do not put a lot of pressure on gun barrel, just enough to hold it safe. Attach hollow end of Valve Tool to threaded section of No. 3437 Outlet seat; hold Valve Tool in vise horizontally and pull gun away to loosen Outlet Valve Seat; you can tap end of gun barrel lightly around the periphery with a wooden mallet to break lead seal. Outlet Valve Seat was screwed down tight against No. 3431 Lead Packing Ring by tightening Outlet Valve Lock Screw against it when gun was assembled, and cannot be removed unless these instructions are followed.

YOU NEED VALVE TOOL for removing parts Nos. 3440-3431-3431-3437-3434, when replacing 3417-3460-3461 Assembly Stud. Insert 3417 Stud inside of large barrel; attach 3461-3460 on outside of barrel; screw 3460 tight.

VALVE ASSEMBLY WILL FALL OUT by inverting gun barrel. If No. 3435 Inlet Valve sticks to Inlet Valve Seat and does not fall out of its own weight, you may be able to jar it loose, by one quick pump on Pump Assembly. Wipe out Air Chamber with a soft cloth, clean or replace both Valves if necessary.

DROP No. 3435 INLET VALVE in Air Chamber with packing against Inlet Valve Seat; next comes No. 3446 Inlet Valve Spring and No. 3447 Valve Spring Washer; then No. 3445 Outlet Valve Spring; next drop No. 3431 Lead Packing Ring in Air Chamber. Attach hollow end of Valve Tool to threaded section of No. 3437 Outlet Valve Seat and screw it down tight by hand; place stem of No. 3434 Outlet Valve in Outlet Valve Seat; insert Outlet Valve and Outlet Valve Seat in Air Chamber, push Valve Tool in (all the way) and hold it there, then Tap end of Valve Tool sharply with hammer; this spreads No. 3431 Packing Ring and holds Outlet Valve Seat in fixed position. Unscrew Valve Tool from Outlet Valve Seat; drop No. 3431 Lead Packing Ring over Outlet Valve Seat. Place No. 3440 Outlet Valve Lock Screw on end of Valve Tool and screw it down on Outlet Valve Seat in Air Chamber; tighten Outlet Valve Lock Screw by turning Valve Tool to spread both Lead Packing Rings. Complete Air Chamber cannot be replaced.

SHOOTING HIGH OR LOW IS NOT A DEFECT and can be easily corrected by drawing a fine or coarse bead on front sight when aiming.

DO NOT CHECK GUNS FOR ACCURACY IN A VISE. Before making any sight correction you should have a shot group of 5 or more shots very close together to make sure that you are aiming and squeezing the trigger properly. Rear Sight No. 3427 has both windage and elevation adjustments. Elevation Adjustment is controlled by pushing elevation bracket No. 3415. Windage is controlled by windage adjustment and screw No. 3415. You cannot check these guns for accuracy in a vise as it would be almost impossible for anyone to replace the gun in exactly the same position after it has been taken out of the vise for pumping up. The practical way to test these guns for accuracy is to put them in a V rest permanently located on a post or other support and bring shot barrel into the same position for each shot by holding it against a stop.

We do not handle Telescopic Sights. We can provide Telescopic Sight Bases only.

No. 273 DETACHABLE REAR PEEP SIGHT ADJUSTABLE FOR ELEVATION AND WINDAGE (includes 1 Disc) available for Models 340-342-347 BENJAMIN AIR RIFLES. Extra Discs Install in 3499 Slot. Remove Open Rear Sight.

TO INSTALL PEEP SIGHT IN 3499 SLOT Loosen 3485 Bolt Lock Cam Screws to permit Elevation Bracket to enter slot, tighten Screws just enough to allow you to move Peep Sight up and down with a little friction to hold it in place; after you have determined position wanted tighten screws securely.

TO ADJUST BOLT LOCK CAM raise Bolt Handle half way or 45° then loosen both Bolt Lock Cam Screws and push Bolt Lock Cam forward to take up any slack; tighten both Bolt Cam Screws securely.

OIL EXTERNAL MOVING PARTS with fine light machine oil to resist wear and rust. Bronze shot barrel will not rust; it is not necessary to clean or oil inside of shot barrel.

YOU WILL NEED 3414 HINGE PIN AND 3415 HINGE PIN BUSHING when replacing 34123 Link Spring or 34103 Pump Link or 34102 Pump Lever.

WE WILL REPAIR WORN GUNS (Bolt Models) at current rates. WE DO NOT ITEMIZE REPAIRS AS IT IS USUALLY necessary to take each gun barrel apart and reassemble it to insure satisfactory operation. We will replace all worn or damaged parts. We will quote cost of repairs needed upon receipt of gun if requested; otherwise we will advise amount due us after repairs are completed. WE DO NOT SHIP C.O.D.; gun will be returned to you by Parcel Post upon receipt of remittance.

WE DO NOT MAKE PARTIAL REPAIRS or assume responsibility or guarantee satisfactory operation unless we make all repairs necessary to put Gun in good working order. Shot Barrel replaced at Factory only; (includes refinishing Gun Barrel) in addition to Repair charges.

SHIP COMPLETE AIR RIFLE BARREL WITHOUT STOCK TO FACTORY, carefully packed, by Parcel Post (or UPS) if you want us to repair it. DO NOT SEAL package against postal inspection and do not enclose any written tags or instructions if shipment is sent by Parcel Post, unless you affix additional postage and endorse Parcel to cover such correspondence.

DO NOT SHIP STOCKS with BENJAMIN Rifles returned to Factory for adjustment or repair as they increase shipping cost both ways; also we are subject to loss or damage in transit.

WRITE FACTORY at the same time shipment is forwarded giving full instructions in each case and enclose previous correspondence regarding same or repeat any circumstances that will assist us, especially if you expect adjustment under our guarantee, or recent repair is not satisfactory. Unless your instructions are in our hands when shipment reaches us, we cannot process repair job in the regular way which entails additional time and expense.

WE CANNOT GUARANTEE FINISH against wearing off, as this is often due to atmospheric conditions or acidity. You can obtain black lacquer or air drying enamel from local paint store for refinishing gun barrel. You can refinish wood handles with clear lacquer or varnish or linseed oil. We do not usually refinish or reblue worn gun barrels or stocks as it is necessary to strip them completely. Our charge for refinishing gun barrel is in addition to cost of repairs; you can order new stocks if wanted.

ORDER AMMUNITION AND OTHER SUPPLIES from Factory if local dealer is unable to supply same. When you inquire about orders for Parts or Tools and Supplies, give us the date on which the order was sent in and enclose another list. Advise amount paid and in what form payment was made--either by Money Order, Bank Draft, Personal Check, Currency, Coin, Postage or Master Charge. If remittance was made by Money Order or Check, ask Postmaster or Bank in your City to investigate whether payment was made to us, and include this information; also enclose previous correspondence if any.

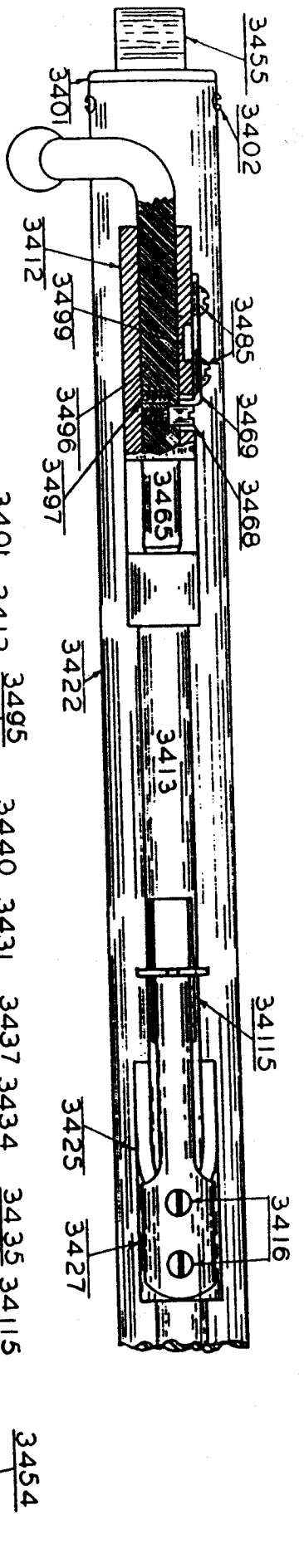

3492 NOT AVAILABLE
REPLACED BY 34092

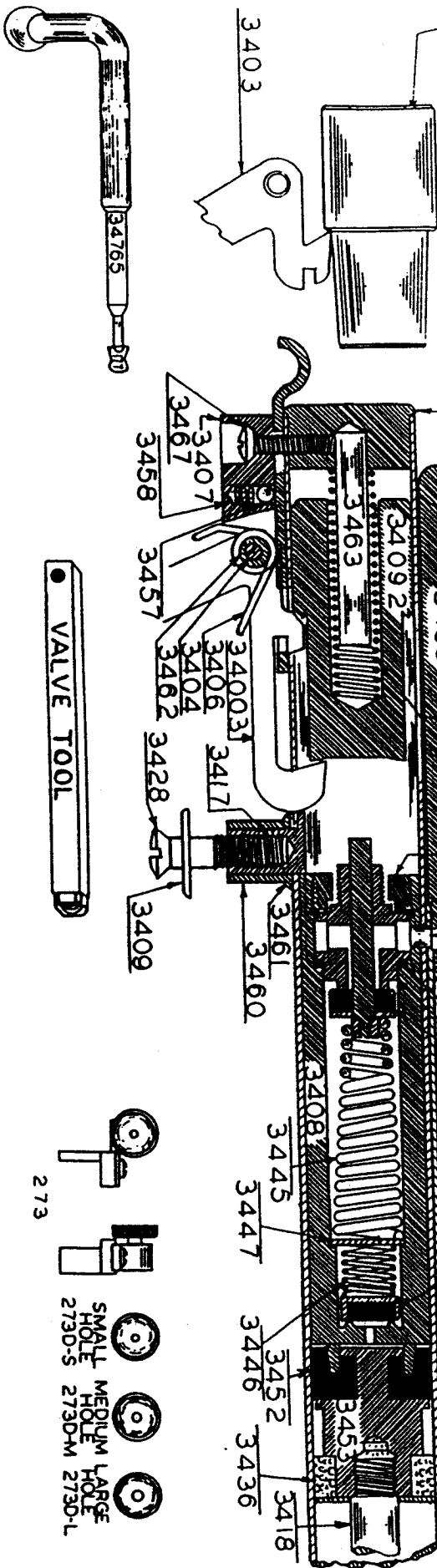

VALVE TOOL

273

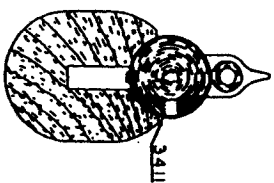
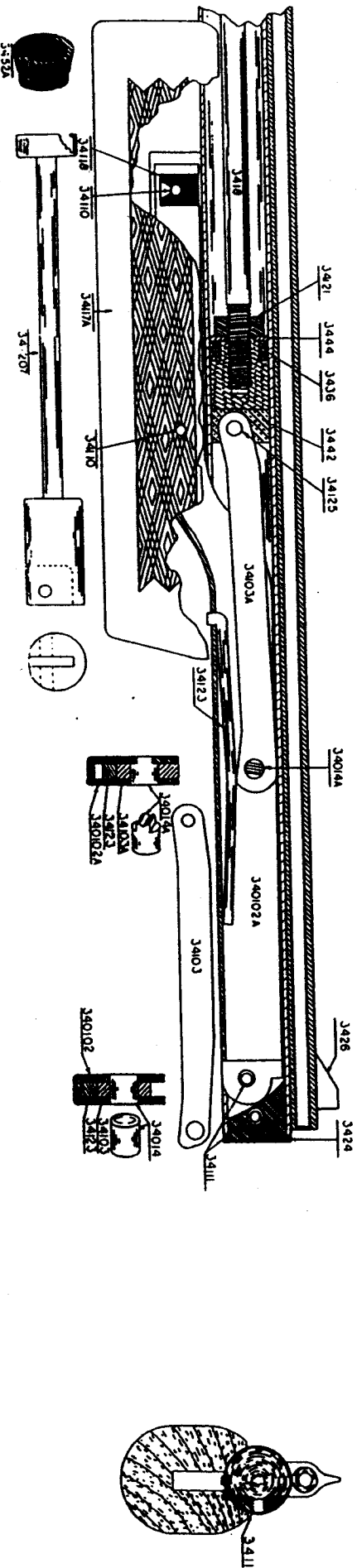
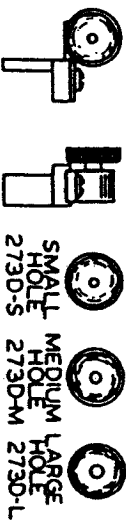

NO. 340-342-347 DESCRIPTION OF PARTS AND PRICE LIST — (Subject to Change)

Parts marked * not subject to replacement — do not order

3401 Breech Cap	3457 Safety Check Ball.....
3402 Breech Cap Screw.....	3458 Safety Spring.....
3403 Trigger With (3462 Trigger Bearing).....	3459 Shot Tube Ferrule.....
3404 Trigger Pin	3460 Assembly Stud Lock Nut (See 3417).....
3406 Trigger Spring.....	3461 Assembly Stud Washer (See 3417).....
3407 Trigger Mount	3462 Trigger Bearing (See 3403).....
3408 Air Chamber	3463 Guide Pin (See 3401)
3409 Stock Washer	3465 Bolt (For Model 340-342)
3411 Air Rifle Shot See Below.....	34765 Bolt (For Model 347).....
3412 Shot Retainer.....	3467 Trigger Mount Screw
3413 Shot Barrel	3468 Bolt Guide Screw
3414 Link Hinge Pin.....	3469 Bolt Lock Cam
3415 Link Hinge Pin Bushing.....	3485 Bolt Lock Cam Screw.....
3416 Sight Screw.....	3492 Hammer
3417 Assembly Stud (3 Parts)(3417-3460-3461)...	3495 Hammer Spring.....
3418 Pump Rod	3496 Bolt Friction Spring.....
3422 Gun Barrel	3497 Ball Bearing
3424 Muzzle Plug	3498 Assembly Screw Washer (For 3428)
3425 Rear Sight Mount	3499 Peep Sight Slot.....
3426 Front Sight (Advise Model)	34003 Trigger with (3462 Trigger Bearing).....
3427 Rear Sight (With 34115).....	34039 Gunstock (not shown) Replaces 3499.....
3428 Assembly Screw (In Stock)	34039 Gunstock complete with 3409-3428-3429-3430-3498.....
3429 Trigger Guard (Not Shown).....	34092 Hammer replaces 3492.....
3430 Trigger Guard Screws (Not Shown).....	34102 Pump Lever (Includes 3414-3415-34103-34123).....
3431 Outlet Port Packing Ring	340102-A (Includes 340102, 34103A, 34123, 34014A).....
3434 Outlet Valve.....	34108 Pump Link
3435 Inlet Valve.....	34110 Lever Handle Pin
3436 Felt Oiler	34111 Lever Hinge Pin
3437 Outlet Valve Seat	34111 Muzzle Plug Pin
3440 Outlet Valve Lock Screw.....	34115 Elevation Bracket
3442 Link Coupling.....	34117 Lever Handle
3444 Small Iron Washer	34118 Rubber Damper
3445 Outlet Valve Spring.....	34121 Pump Rod Lock Nut.....
3446 Inlet Valve Spring.....	34123 Link Spring (See 3414-3415)
3447 Valve Spring Washer.....	34125 Link Coupling Pin.....
3452 Hycar Pump Washer	34207 Pump Rod Assembly (Replaces 3418-3436-3442-3444-3452-3453-3454-34121).....
3452-A Hycar Pump Washer	
3453 Pump Fitting	
3454 Felt Oiler Lock Washer.....	
3455 Safety	

YOU CAN ORDER AMMUNITION AND SUPPLIES FROM FACTORY if your local Dealer is unable to supply same.

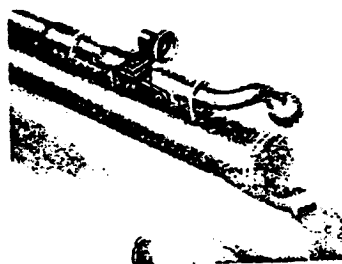

No. 273 Detachable Rear Peep Sight with (1) Disc-Small, Medium or Large Hole- Advise Model ...			
Extra Discs			
No. B-270 Telescopic Sight Bases for Models 340-347			
No. B-272 Telescopic Sight Bases for Model 342			
BENJAMIN H-C PELLETS, Cal. .22	1000-	500-	250 ..
BENJAMIN H-C PELLETS, Cal. .177	1000-	500-	250 ..
BENJAMIN Steel Air Rifle Shot, in cans 1 lb. (Approx. 1250)			
BENJAMIN Lead Air Rifle Shot, in cans 1 lb. (Approx. 850)			
BENJAMIN Steel Air Rifle Shot (500)			
BENJAMIN Lead Air Rifle Shot (500)			
BENJAMIN DARTS .22 Cal. (Not Available)			
BENJAMIN DARTS .177 Cal.			Doz.
BENJAMIN BULLS-EYE BELL TARGET			
BENJAMIN PAPER TARGET INSERTS	1000-	500-	100 ..
VALVE TOOL For removing Outlet Valve Lock Screw and extracting Outlet Valve Seat			

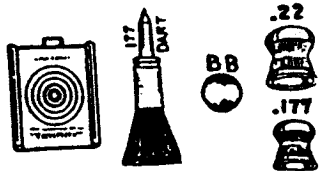

MINIMUM ORDER \$5.00. MAY INCLUDE PARTS, AMMO AND ACCESSORIES SHIPPED PREPAID.

ENCLOSE PAYMENT WITH DIRECT ORDERS TO BE SHIPPED FROM FACTORY.

ALLOW TIME FOR PERSONAL CHECKS TO CLEAR. Send Money Order, Postal Note, Bank Draft or Master Charge with orders if prompt shipment is wanted. We will not assume responsibility for loss of Currency or Coin or Stamps included with orders by regular mail. Include Sales Tax with orders from Mo. WE DO NOT SHIP C.O.D.

“Benjamin Air Rifle Company is not responsible on its warranty to any purchaser or user who tampers with, modifies or uses this product for any other purpose than that for which it was intended.”